



1

## What is the Z-PORT® invention ?

SCnewton Inc. has invented an advance software controlled High Voltage Electrical Hardware:

Called:



ZPORT



# What does Z-PORT® do?

Z-PORT® enables two stages of performance with only single stage mechanical gear

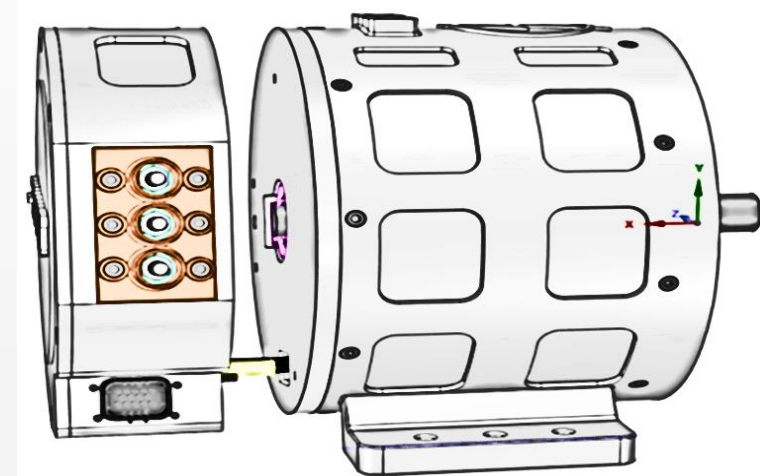
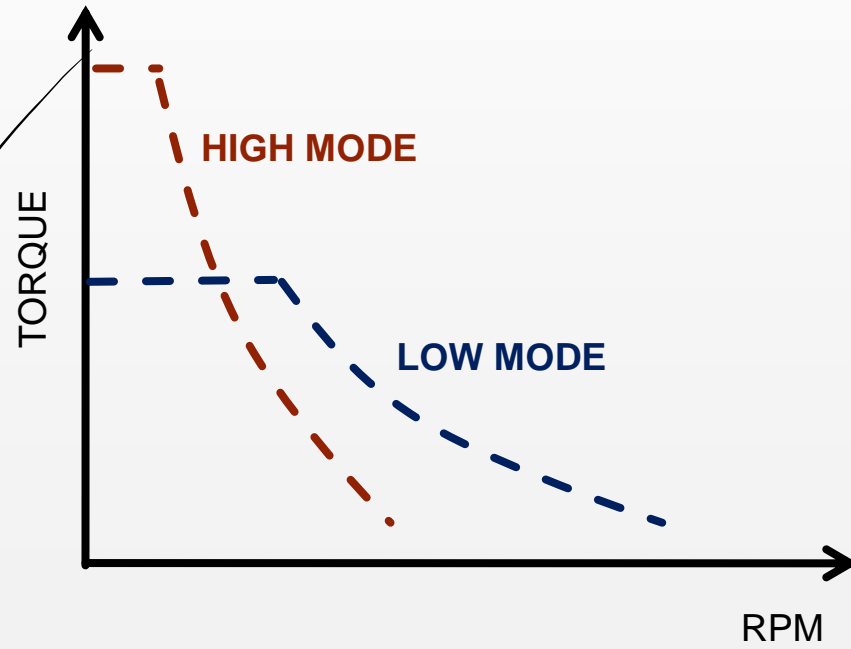

**Z-PORT®** + E-motor Assembly =





# What is the Z-PORT® mechanism?

## ✓ Shifting the Motor Windings Under High Current!

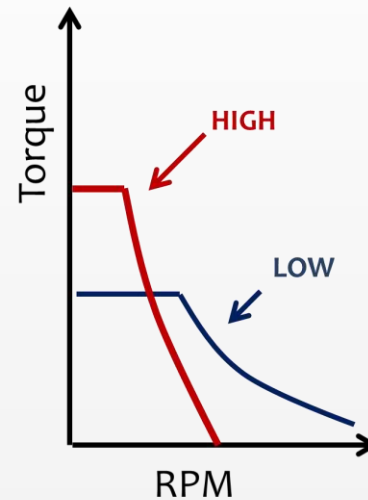
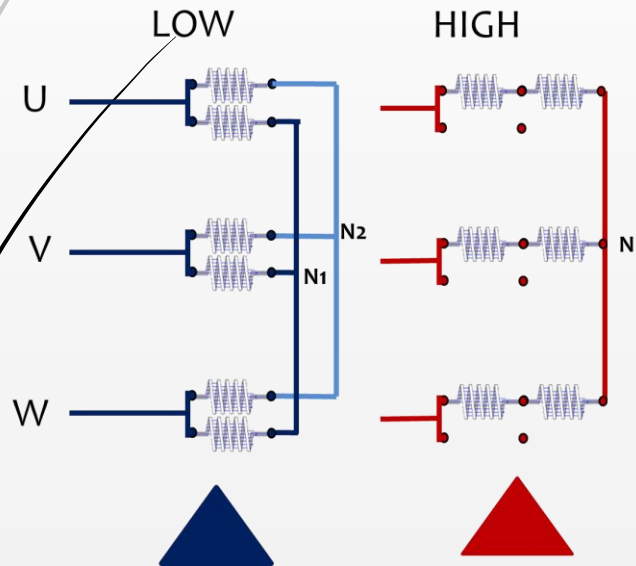

- ❖ Transition time < 300ms
- ❖ EDM Torque and speed ripple during shift < 1%
- ❖ Efficiency > 99.5%
- ❖ Up to 2500 VRMS, 650ARMS-10 sec.
- ❖ Max Operating Temp. 200 C.
- ❖ NO over-voltage transients!
- ❖ NO loss of power!
- ❖ ASIL-D compliant!
- ❖ 40kW/kg!
- ❖ Modular design!



# How does the Z-PORT® integration look like?

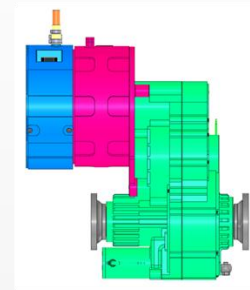
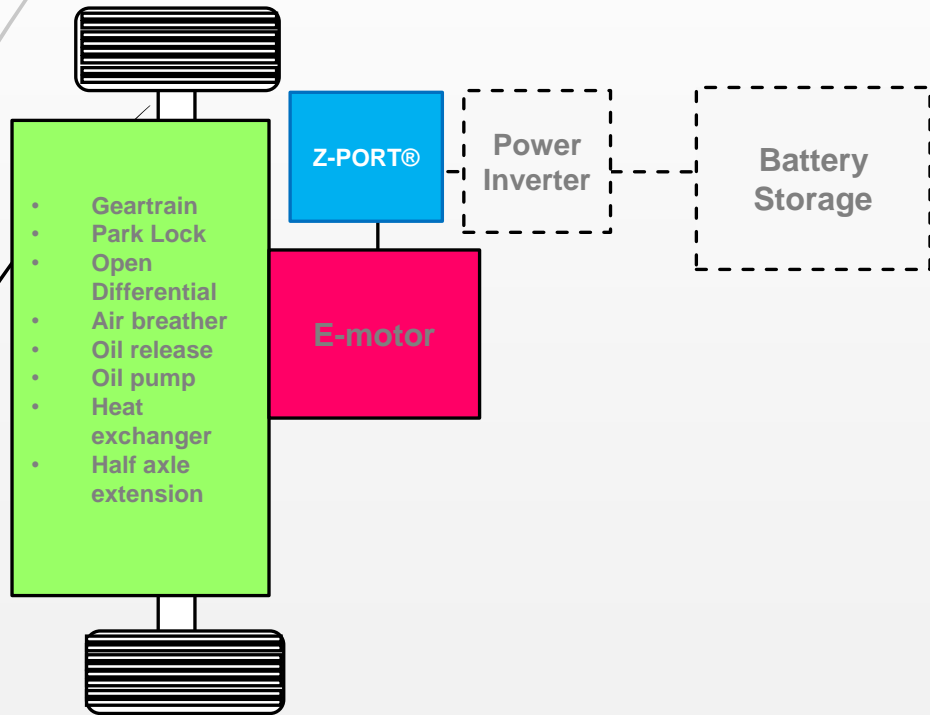

Z-PORT

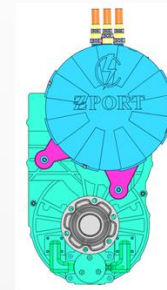

E-MOTOR

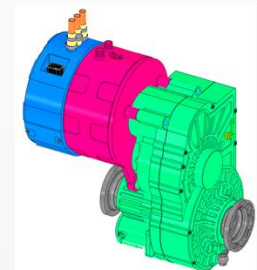

GEAR-BOX



# What are two stages of Z-PORT® Performance?

101- BASE MOTOR PERFORMANCE  
102-PERFORMANCE-ZPORT ON HIGH

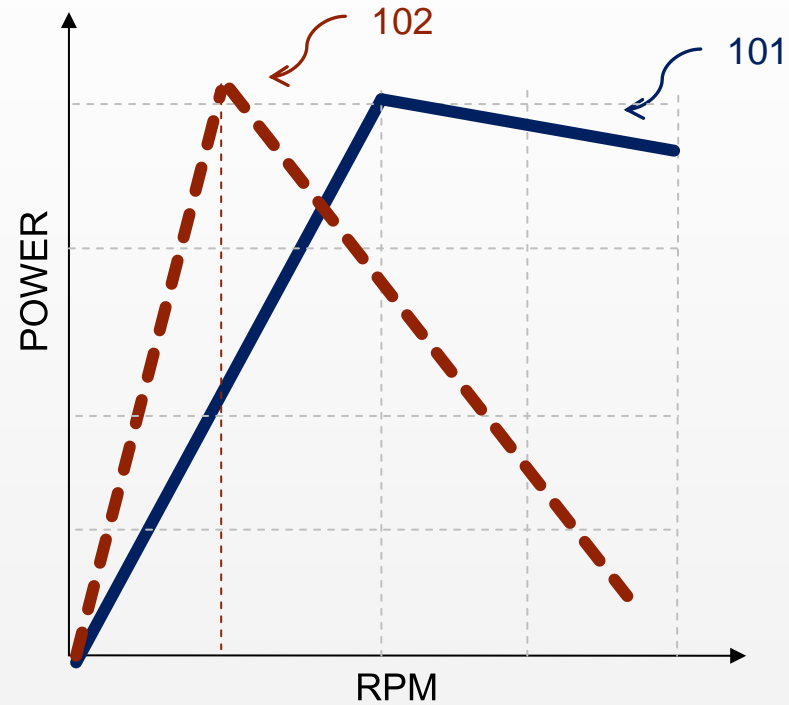
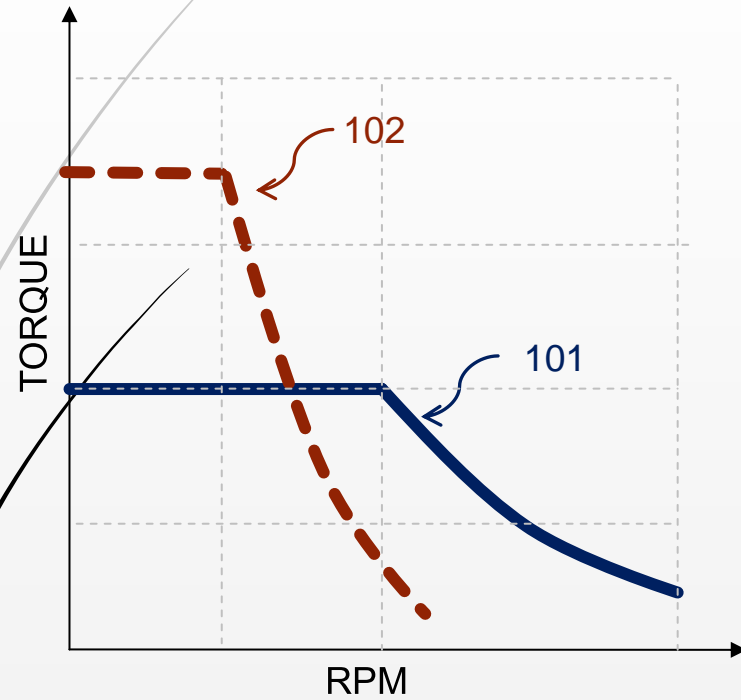

Performance boosting without the need for extra current from battery and power inverter module



# An example of Z-PORT<sup>®</sup> performance on PMSM:

- 101- BASE MOTOR PERFORMANCE: 450 ARMS-15 SEC.
- 102- PERFORMANCE Z-PORT ON HIGH: 450ARMS-10 SEC.
- 103- BASE CONTINUOUS PERFORMANCE: 200ARMS- INF.

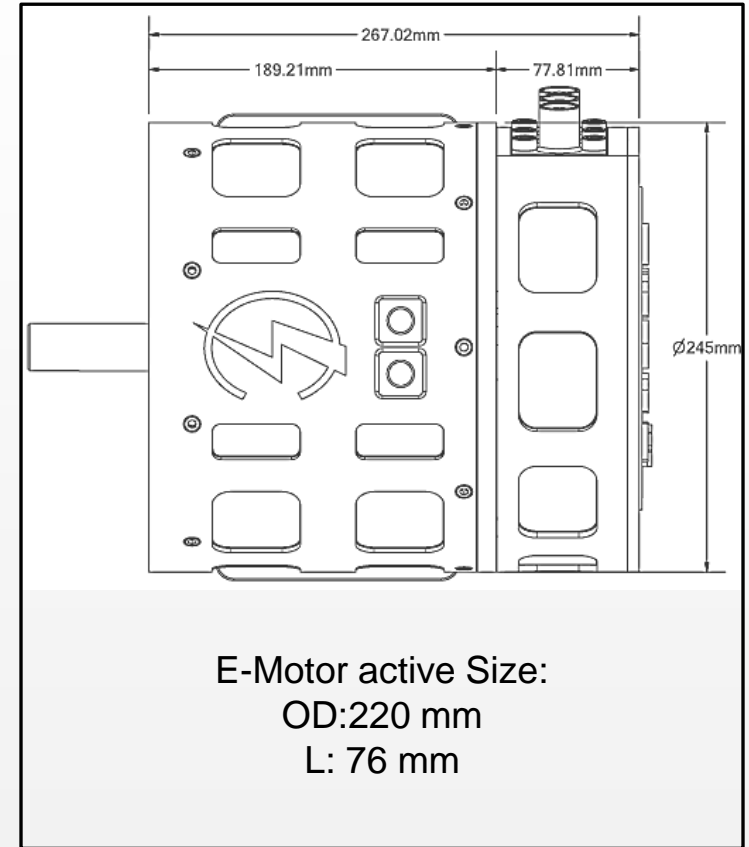
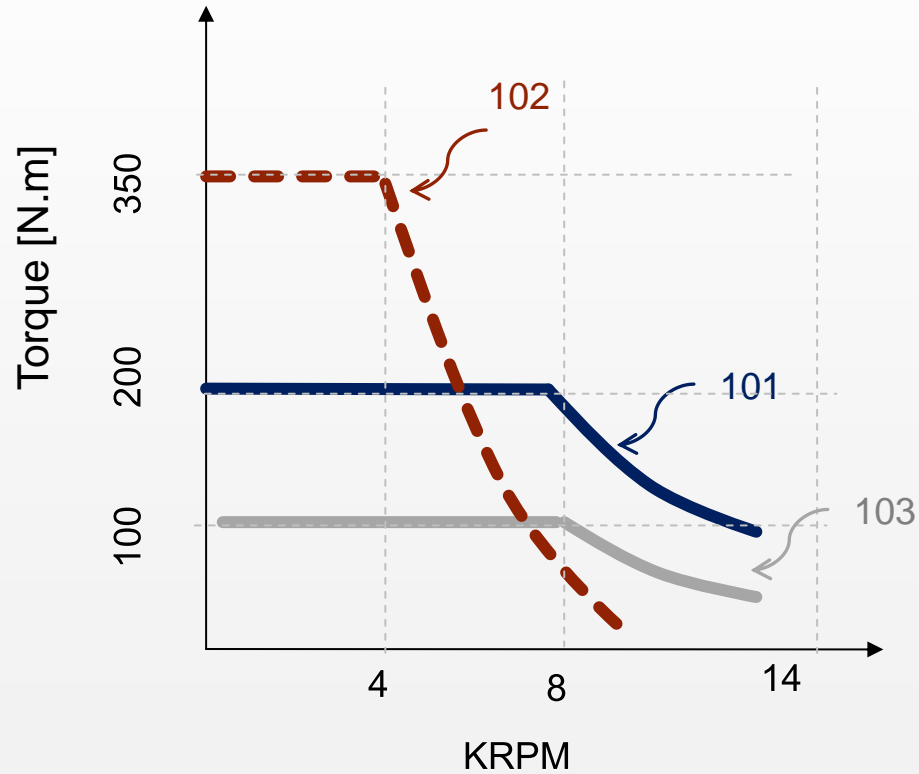



# What are the Z-PORT® commercial value propositions?

NON-PREMIUM EDM < 2kW/Kg		
WITHOUT Z-PORT	USD/kW	10
<b>WITH Z-PORT</b>	<b>USD/kW</b>	<b>8.8</b>
WITHOUT Z-PORT	USD/PEAK N.m	5
<b>WITH Z-PORT</b>	<b>USD/PEAK N.m</b>	<b>3.14</b>

PREMIUM EDM > 2kW/Kg		
WITHOUT Z-PORT	USD/kW	15
<b>WITH Z-PORT</b>	<b>USD/kW</b>	<b>12.8</b>
WITHOUT Z-PORT	USD/PEAK N.m	7.5
<b>WITH Z-PORT</b>	<b>USD/PEAK N.m</b>	<b>4.57</b>

## Adoptable :

- Works on any motor type

## Modular :

- Modular Design (plug-and-play)
- Ease of Integration to Common Powertrain Platform

## Catalyst :

- Vehicle platform mutation